

Ag84Mr

# METHODS AND FACILITIES FOR GRADING BROILERS AND TURKEYS

U.S. DEPT. OF AGRICULTURE  
NATIONAL AGRICULTURAL LIBRARY

MAR 12 1979



UNITED STATES  
DEPARTMENT OF  
AGRICULTURE

MARKETING  
RESEARCH  
REPORT  
NUMBER 1091

PREPARED BY  
SCIENCE AND  
EDUCATION  
ADMINISTRATION



## Historic, archived document

Do not assume content reflects current scientific knowledge, policies, or practices.

On January 24, 1978, four USDA agencies--Agricultural Research Service (ARS), Cooperative State Research Service (CSRS), Extension Service (ES), and the National Agricultural Library (NAL)--merged to become a new organization, the Science and Education Administration (SEA), U.S. Department of Agriculture.

This publication was prepared by the Science and Education Administration's Federal Research staff, which was formerly the Agricultural Research Service.

Science and Education Administration  
In Cooperation With  
Food Safety and Quality Service  
UNITED STATES DEPARTMENT OF AGRICULTURE

---

For sale by the Superintendent of Documents, U.S. Government Printing Office  
Washington, D.C. 20402

Stock Number 001-000-03803-6

## PREFACE

This report describes methods and facilities utilized in existing plants to grade whole ready-to-cook broilers and turkeys and includes various types of grading facilities acceptable to the U.S. Department of Agriculture.

Appreciation is expressed to James B. Skinner, National Supervisor of Poultry Grading, Poultry and Dairy Quality Division, Food Safety and Quality Service, for his guidance and technical contribution throughout the study,

Also, appreciation is expressed to the management and resident graders for their cooperation at the 18 processing plants analyzed in this study.

The research was conducted under the direction of T. F. Webb, Chief, Animal Products Marketing Laboratory, Science and Education Administration.

## CONTENTS

	Page
Abstract -----	1
Introduction -----	1
Procedure -----	3
Guidelines for examining birds and parts -----	3
Methods and facilities for grading broilers -----	4
Plant A -----	4
Description -----	4
Suggested improvements -----	6
Plant B -----	7
Description -----	7
Suggested improvements -----	13
Plant C -----	13
Description -----	13
Suggested improvements -----	16
Methods and facilities for grading turkeys -----	16
Plant D -----	16
Description -----	16
Suggested improvements -----	20
Plant E -----	21
Description -----	21
Suggested improvements -----	24
Plant F -----	25
Description -----	25
Suggested improvements -----	28
Literature cited -----	28
Appendix -----	29
Poultry grading regulations -----	29
Grading facility and equipment requirements -----	29

# METHODS AND FACILITIES FOR GRADING BROILERS AND TURKEYS

By Clarence E. Harris<sup>1/</sup>

## ABSTRACT

Methods and facilities for grading whole ready-to-cook broilers and turkeys were analyzed in 18 commercial processing plants, where the grading was performed under the supervision of USDA licensed resident graders.

Six plants were selected as representative of those with grading methods and facilities used extensively in the poultry industry. Data from each plant were analyzed for desirable and undesirable features that could affect accurate and efficient product grading or contribute to fatigue, inconvenience, and discomfort of the graders. Facilities at or near the sorting and grading areas are described and illustrated to show structural details that can affect grading operations.

Guidelines are provided for those planning to process and pack products under the grading service to assist them in minimizing undesirable features that could contribute to lower levels of grading accuracy and efficiency.

The report describes grading methods and facilities in three broiler and three turkey processing plants. Included in the appendix are excerpts from the regulations governing poultry grading, information from the "Poultry Graders Handbook" on facilities and equipment required for resident Federal-State graders, and a summary of quality specifications for individual carcasses of ready-to-cook poultry and parts. A copy of Form PY-140, Plant Survey for Poultry Grading, is also included to illustrate some of the necessary items that must be satisfactory prior to instituting grading service.

## INTRODUCTION

The purpose of this report is to describe operations and facilities that will contribute to improved accuracy and efficiency in broiler and turkey grading. This information can benefit the consumer and the processor and enable the graders to perform more competently.

Nearly 80 percent of the poultry processed in U.S. federally inspected plants is graded. In 1975, these plants processed over 10 billion pounds of

---

<sup>1/</sup> Animal Products Marketing Laboratory, Beltsville Agricultural Research Center, Beltsville, Md. 20705.

product. Most of the grading is performed by licensed or authorized graders on a resident basis. In 1976, 296 plants had USDA resident graders. Since about 1974, the trend has been toward a higher percentage of the product being officially graded because consumers and retailers are more aware of U.S. grade A products.

Many processors have been increasing their line speeds and thus have restricted the time that graders have to analyze the product. Therefore, a practical work-station layout and adequate facilities become more critical if grading is to conform to national uniform standards established by the U.S. Department of Agriculture (USDA). A high degree of accurate and efficient grading can be advantageous to the processor by (1) improving the product's image, (2) yielding a higher return for the product since a premium price is normally received for a grade A product, and (3) increasing the productivity per man-hour of the firm's personnel, since much of the grading is done by authorized graders<sup>2/</sup> employed by the firm. The final grade is determined by the resident grader on an AQL<sup>3/</sup> check grading basis.

Well-planned work stations eliminate wasted motion, increase output and accuracy without increasing the operator's effort, reduce fatigue, improve plant housekeeping, permit easier supervision since clutter and congestion in and about the individual work stations are eliminated, improve safety, and raise employee morale (5).<sup>4/</sup> Employee productivity is affected by temperature, humidity, and ventilation of work areas. A well-planned layout provides safe, satisfactory, and efficient working conditions. Firms that provide and maintain such conditions can expect less labor turnover and absenteeism (2).

The most frequent reasons for downgrading birds are for (1) breast blisters (trimming), (2) cuts and bruises, and (3) broken bones and torn skin (1).

A plant processing 100,000 birds daily and receiving 2 cents per pound less for undergrade birds would lose \$13,750 annually for each 1 percent of its product downgraded. Therefore, providing well-planned work-station layouts and proper equipment is essential, with adequate assistance and facilities for reconditioning<sup>5/</sup> birds to meet grade A requirements.

USDA regulations governing the grading of poultry products are not designed to describe in detail the facilities and equipment needed for accurate and efficient grading. Facilities and equipment vary extensively from plant to plant. The "Poultry Graders Handbook" (6) elaborates more extensively

---

<sup>2/</sup> Company employees trained to grade according to U.S. standards. They perform official grading under the supervision of a licensed USDA resident grader.

<sup>3/</sup> Acceptable quality level.

<sup>4/</sup> Underlined numbers in parentheses refer to Literature Cited, p.28.

<sup>5/</sup> Reconditioning is the bringing of products into condition for grading by removing feathers or other items that prevent the product from being ready-to-cook.



on the facilities and equipment required for resident grading service (see appendix).

## PROCEDURE

The grading operations were observed in 11 broiler and 7 turkey processing plants throughout the country to determine the work methods and equipment combinations commonly used in the industry. Then three broiler and three turkey processing plants were selected as examples of different types of grading operations. The diversity of those operations was so extensive that the scope of the study had to be restricted to grading whole ready-to-cook broilers (fryers)<sup>6/</sup> and turkeys, since these operations were the most widespread in the industry.

The plants selected for the study were not judged to be ideal, but they were chosen because they exemplified a relatively high level of accurate and efficient grading operations and were representative of acceptable types of facilities and equipment.

Data were collected and drawings prepared of the principal equipment and its arrangement in each plant. Inasmuch as possible, equipment not related to grading nor moving the product to and from the work area was excluded from the drawings. Each grading operation was evaluated to determine its desirable and undesirable attributes and improvements were suggested.

## GUIDELINES FOR EXAMINING BIRDS AND PARTS

The grader should have the bird at a distance from his eye approximating that used for reading. Graders who require reading glasses should use them in grading since minute pinfeathers, hairs, and small wet feathers are particularly hard to see on white-feathered birds. The grading area should be illuminated by at least 50 foot-candles of light and should be located where cross-traffic and distracting noises are at a minimum.

All birds or parts should be examined in their entirety before making a final decision on the quality. The usual procedure is to decide on the fleshing and fat cover first. This makes it easier to decide on the other characteristics. For example, a poorly fleshed bird should not be examined for other qualities because it would not meet grade A requirements for fleshing.

When birds are graded out of bins, the poultry carcass is examined by grasping the hocks of the bird in one hand with the breast up. In this position, the grader can easily observe the breast, wings, and legs, and by a mere twist of the wrist the back of the bird can be turned into position to be

---

<sup>6/</sup> A broiler or fryer is a young chicken, usually under 13 weeks old, of either sex. It is tender meated, with soft, pliable, smooth-textured skin and flexible breastbone cartilage.

observed. The various quality factors are appraised and the bird is placed in the proper grade bin.

When birds on a conveyor line are graded, the breast side of the bird is examined first. The carcass is then turned to examine the remainder. In some instances, the birds are removed as they are graded and placed in the various quality bins or cooling tanks. At other times, only A quality carcasses are removed and others are taken off the conveyor line later, or the lower quality carcasses are removed and only grade A carcasses remain on the conveyor line.

The procedures for grading ready-to-cook poultry carcasses on a conveyor belt also apply to grading the parts.

Poultry carcasses and parts cannot be given a consumer grade unless each carcass or each part is graded individually in a fresh state. Frozen poultry carcasses or parts may be examined for condition to determine that the product has maintained its original quality and does not have freezing defects. Frozen poultry carcasses or parts that were not graded in a fresh state may be graded and the lot assigned a procurement grade.

Proficient graders can evaluate carcasses at a glance, keeping in mind each of the quality factors; they can make split-second decisions on these factors and place the carcasses in the various quality grades.

## METHODS AND FACILITIES FOR GRADING BROILERS

### Plant A

#### Description

About 12 million broilers are processed annually in plant A. Approximately 75 percent are marketed as whole ready-to-cook birds packed in ice and the remaining 25 percent are cut up. Grading is performed by a USDA licensed resident grader and three authorized graders.

Grading is primarily an in-line system in plant A. Figure 1 shows the layout of the grading area and arrangement of the equipment. The birds are suspended from nonrotating sizing shackles by one hock and are transported by a continuous overhead conveyor. It is normally operated at approximately 100 shackles passing the grading station per minute. As the birds pass before the graders, they are graded according to U.S. grade standards. The grade A product is allowed to remain on the conveyor, and undergrades are removed and placed in designated pans. Each shackle has an identification, such as a color code or tag, so that each of the three graders can select every third bird for grading. The identification is readily visible to avoid needless eye movement to the top of the shackle, since this can detract from the grading function.

Occasionally a fourth person is employed to place wing tags on each grade A bird at a work station between the last grader and the table shown in figure 1.

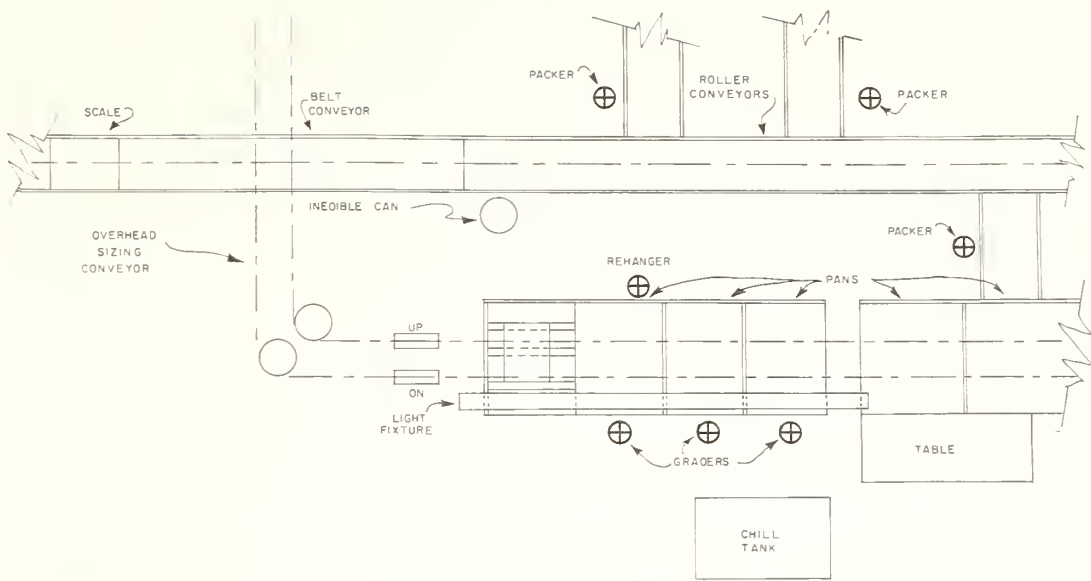

TOP VIEW

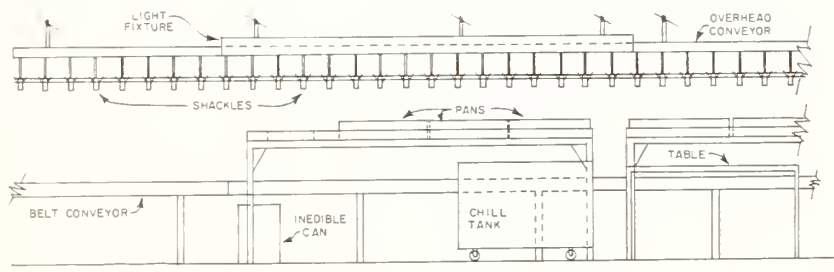

SIDE VIEW

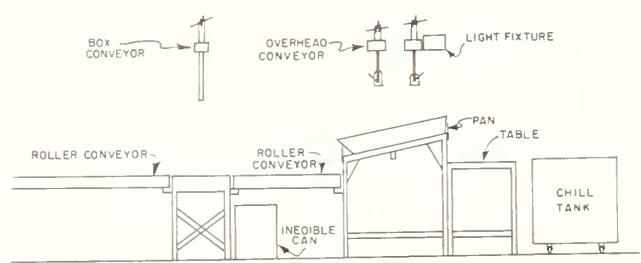

END VIEW



Figure 1.--Layout of broiler grading area in plant A.

The grade A birds continue along the conveyor to sizers, where they are dropped into the proper pan. The undergrade birds are rehung on the overhead conveyor and transported to a cut-up operation in another part of the plant, whereas birds needing reconditioning are dropped into the chill tank behind the graders.

The desirable features of this grading area are as follows:

- (1) Space is adequate around the graders.
- (2) Birds are presented at such a height that the graders can easily see the entire carcass.
- (3) The layout necessitates only limited separation of undergrade birds. Once the graders have decided that a bird is an undergrade, they do not have to select from several choices in disposing of it.
- (4) Each grader is required to grade approximately the same number of birds because of the identified shackles and the uniform pacing by the overhead conveyor.
- (5) Adequate adjacent space and facilities are provided for reconditioning birds to meet grading requirements.
- (6) Lights extend the full length of the grading area.
- (7) The hook of the shackle is turned toward the graders and thus does not obscure their vision of hock bruises and discolorations.
- (8) The sloped pans keep the undergrade birds away from the graders.

The undesirable features of this grading area are as follows:

- (1) The top of the pans restricts the graders' accessibility to the birds; they have to reach over the pans to get the birds.
- (2) The light fixture is too far in front of the graders so that the light shines in their eyes.
- (3) The shorter employees require foot stands.

#### Suggested Improvements

The normal working height when grading from an alternate sitting-standing position is 37 inches above the floor or platform for women and 47 inches for men (4).

In plant A, the top of the pans for undergrade birds is 48-1/2 inches and the overhead conveyor shackles are 60 inches above the floor at the grading stations and at the opposite side of the pans where the undergrade birds are rehung on the overhead conveyor (cut-up line).

At the grading stations, the top of pans restricts the graders' accessibility to turn the birds around and to lift the undergrades from shackles since the top is 48-1/2 inches high. However, the shorter graders normally use a foot stand, which is usually 8 inches or less in height for safety reasons. Thus, when the short person is raised to a working height of 45 inches, the top of the pans is 3-1/2 inches too high. The pan height is more convenient for men, but even for them the pans are too high.

To alleviate the height problem for the short graders and to make the birds more accessible to others, the overhead conveyor could be raised 6 to 10 inches and a platform with a guardrail around it could be installed in the grading area. This platform should be wide and sturdy to insure safety and it could have adjustable legs so it could be raised or lowered to satisfy the graders' needs. Raising the overhead conveyor by 6 to 10 inches would bring the breast of the birds, suspended from the shackles, to the approximate eye level of graders. For women this is 58 inches from the floor (4).

Since the light fixture is too close horizontally to the overhead conveyor so that it shines into the eyes of the graders, it should be moved away from the overhead conveyor and raised to 6 feet 8 inches above the floor.

Another way to improve the grading operation is to provide more space between graders. In plant A, the pans for undergrade products are 30-1/2 inches apart and tend to limit the workspace for each grader to that width. With the shackles 6 inches on center and the overhead conveyor traveling at 100 shackles per minute past a given point, the grader has only 3 seconds per bird to perform his task when confined to 2-1/2 feet, whereas when the grader has 3 feet of space, he will have 3-3/5 seconds. Therefore, at least 3 feet of space should be provided for each grader. This can be accomplished by moving the table for wing tags and separating the three pans for undergrade birds to 6 inches or more or by using wider pans.

## Plant B

### Description

Approximately 28 million broilers are processed annually in plant B. They are marketed as whole ready-to-cook birds and as cut-up and further processed products. Grading is supervised by two USDA licensed resident graders. They are assisted by eight authorized graders, who sort<sup>7/</sup> the birds as they are discharged by the chilling machines, and by other authorized graders, who grade the birds as they are being conveyed by an overhead conveyor (the drip line) at a point just before the giblet stuffing operation. The cut-up product is graded by other authorized graders.

Figure 2 shows the layout of the sorting area, located at the exit end of the chilling machines, and figure 3 the layout of the grading area, located at a point just prior to the giblet stuffing operation.

---

<sup>7/</sup> Sorting is the removal prior to grading of obvious undergrades.



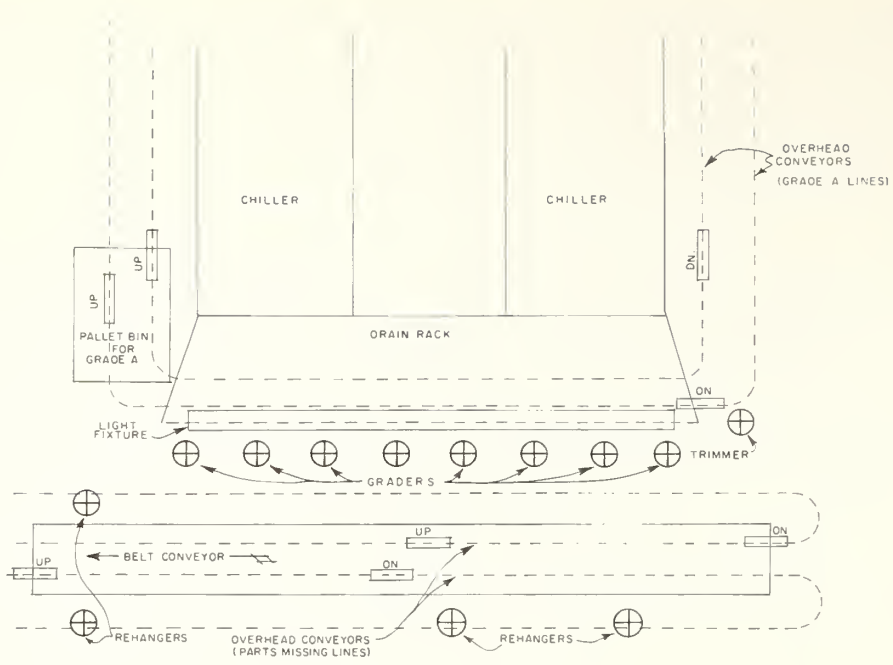

TOP VIEW

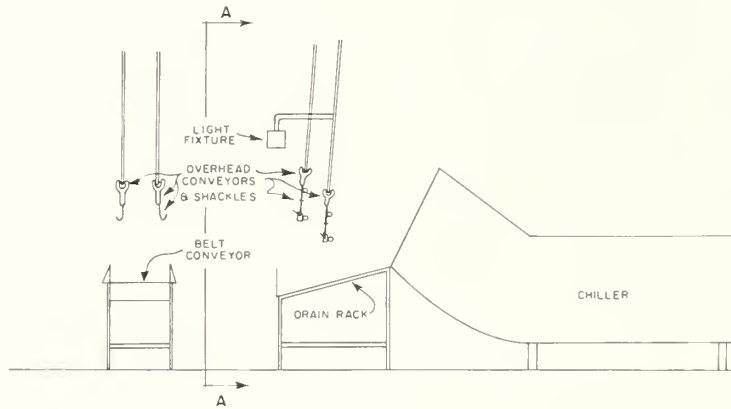

SIDE VIEW

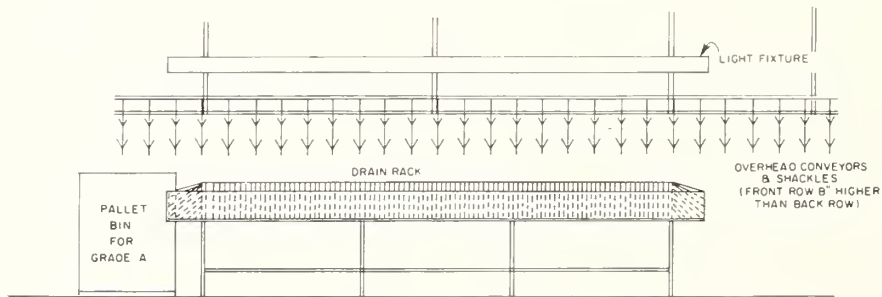

SECTION AA



Figure 2.--Layout of broiler sorting area in plant B.

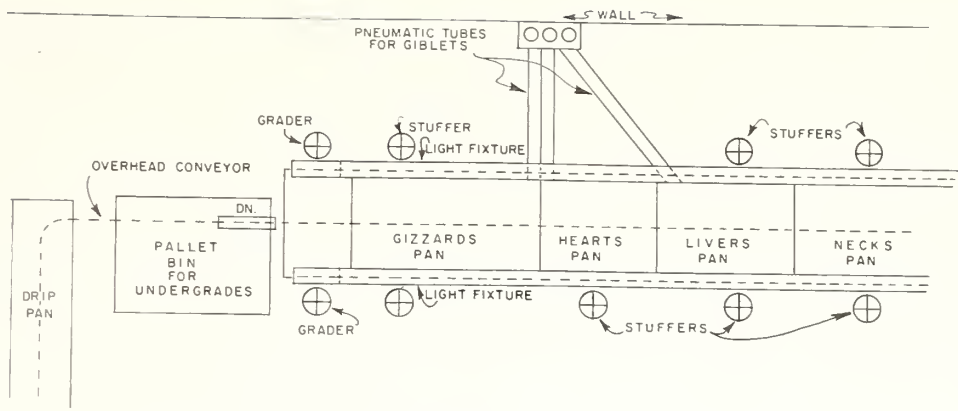

TOP VIEW

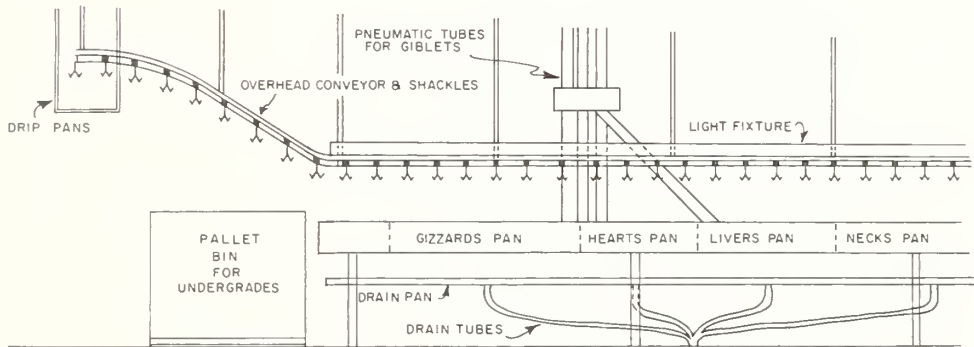

SIDE VIEW

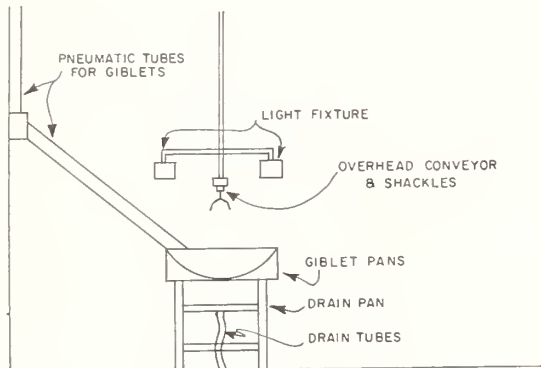

END VIEW



Figure 3.--Layout of broiler grading area in plant B.

In plant B, the birds are sorted as part of the function of transferring them from the chillers to the overhead conveyor (fig. 4). Those birds determined to be undergrades at the chiller drain rack are tossed onto a belt conveyor (fig. 5) located 3 feet from the drain rack and then hung on the overhead conveyor (cut-up line). The chiller drain rack area, where the birds are sorted, is well lighted by overhead fluorescent lamps covered with shields.

Grading is performed on an overhead conveyor by two authorized graders (fig. 6). Undergrade birds removed from the conveyor at the point just before the giblet stuffing operation are dropped into a pallet bin, where, after accumulation, they are transported to another area of the plant and hung on an overhead conveyor for the cut-up operation.

The grade A birds are moved to the giblet stuffing operation and then dropped into pans, from which they are packed in shipping containers.

The birds are suspended from shackles on the overhead conveyor by both hocks. Two shackles are welded to a bent stainless steel rod and attached to the overhead conveyor by a pendant. The birds are hung back to back with the breast side toward the graders. The shackles are 9 inches on center and the overhead conveyor (drip line) is approximately 200 feet long, with drip pans under about two-thirds of the line.



PN-6240

Figure 4.--Hanging birds at the drain rack.





PN-6241

Figure 5.--Undergrade birds collected on the belt conveyor are transferred to overhead conveyors (cut-up line).

The desirable features of the sorting and grading areas are as follows:

(1) Each bird is checked twice, once at the sorting and again at the grading area.

(2) The layout minimizes the grading decisions to be made. At the sorting area, if the birds are judged to be undergrade regardless of the reason, they are dropped onto the belt conveyor behind the sorting area. Likewise, at the grading area, if a bird is judged to be undergrade for any reason, it is dropped into a nearby pallet bin.

(3) Each grader is required to grade about the same number of birds and they are paced by the moving line.

(4) The space on one side of the grading line is adequate for reconditioning birds to meet grading requirements.

(5) The view of the breast of the birds at the grading area is satisfactory.



PN-6242

Figure 6.--Grading by authorized graders.

The undesirable features of the sorting and grading areas are as follows:

- (1) The grader has difficulty seeing the back of the birds, because they are suspended from the overhead conveyor by nonrotating shackles.
- (2) Undergrade birds are not easy to remove from the shackles.
- (3) One of the grading positions has inadequate space for grading and not enough room adjacent to it for reconditioning the product.
- (4) Each grading position is only 24 inches wide.
- (5) Since the floor is not well drained at the grading area, the graders stand on platforms, where their eye level is at about the height of the shackle rather than the bird.
- (6) The grading area is not well lighted.
- (7) Birds accumulate to an excessive depth in the drain rack at the sorting area and contribute to the inefficiency of sorting and hanging the birds and increasing the probability of some of them being left in the rack for extensive periods.

(8) The drain rack is approximately 17-1/2 feet long, with less than 2 feet of workspace for each of the eight graders and one trimmer.

(9) The overhead conveyor passes in front of all nine workers at a higher elevation as it goes out and at a lower elevation when it returns, traveling at approximately 250 shackles per minute. Once a grade A bird has been selected, the sorter often has to wait for an empty shackle, especially sorters near the middle of the drain rack. Trying to hang a bird on a fast-moving conveyor line is awkward and inefficient.

### Suggested Improvements

The sorting area is too congested. One way to alleviate this problem is to provide more drain rack space or frontage. This could be accomplished by moving the chillers farther apart and adding more rack in that area; however, moving the chillers probably would be costly, both in moving expense and wasted floorspace between the chillers. Another way to get more rack space would be to extend the rack at either end using deflectors or belt conveyors to move the birds out the ends. Complete separation of the two hanging areas, with separate slower moving overhead conveyors, would probably facilitate the highest degree of efficiency; however, this alteration also would be costly. In many other plants the sorting and hanging are performed from a belt conveyor moving in the same direction as the overhead conveyor. Usually the birds slide onto the moving belt conveyor as they come out of the chiller, moving along the conveyor until they are on the overhead conveyor shackles or dropping into a chill tank at the end of the belt. This might be more efficient than the present system.

The grading operation in plant B could be improved by increasing the width of the grading stations and improving the floor drainage in the area or raising the height of the shackles at the grading stations. The taller graders have difficulty seeing the lower half of the birds, and if the floor were well drained, these graders could stand on the floor rather than on the platforms. Also, fluorescent or other approved lamps should be installed on each side of the grading line (fig. 3) at a height of 6 feet 8 inches and about 3 feet from the overhead conveyor, and they should provide at least 50 foot-candles of light (3).

## Plant C

### Description

Approximately 26 million broilers are processed annually in plant C. About 80 percent are marketed as whole ready-to-cook, ice-packed birds and about 20 percent as cut-up, tray-packed chicken parts. Grading is supervised by a USDA licensed resident grader assisted by 12 authorized graders. The primary function of the first grader on each line is to sort the birds just prior to grading, removing those with missing parts and trimmed areas.



Grading of whole birds is performed along two belt conveyors near the discharge end of the chillers. After birds are lifted by conveyors from the chillers, they are rolled down an inclined ice separator to the grading belt conveyor, with the ice falling into a chill tank under the ice separator.

As the birds pass along the two 25-foot belt conveyors (fig. 7), each one is lifted from the belt and graded. Those meeting the grade A standards are hung by a hook in shackles on an overhead conveyor, which takes them to the sizer located in another area of the plant. The undergrade birds are tossed into stainless steel holding pans, 17 feet 8 inches long and 2 feet wide, alongside the belt conveyors. From the holding pans, the birds are rehung on shackles of the overhead conveyor for undergrades. Both overhead conveyors serve as drip lines. Giblets are stuffed in the grade A birds before sizing.

The shackles on the grade A line are 18 inches above the belt conveyor and 9 inches on center. Likewise, the undergrade line is 14 inches above the top of the holding pans and 9 inches on center. The grade A line is 14 inches from the front side of the belt conveyor and the undergrade line is 16 inches from the outside edge of the holding pan.

Platforms 5 inches high, 16 inches wide, and 18 feet long are along each of the grading belt conveyors for the graders. The conveyor is 3 feet above the floor.

The desirable features of this grading area are as follows:

(1) The grading area has an adequate amount of space. Each grader has at least 3 square feet of floorspace.

(2) The platforms are ample in width and length with nonskid surfaces.

(3) Light fixtures are located to maximize the quantity of light on the birds and to restrict the quantity of light shining in the graders' eyes.

(4) The 3-inch-high side rails on the belt conveyor are sufficient to keep the birds on the belt without obstructing the graders' accessibility to the birds to be graded.

(5) Shackles on the overhead conveyors are 18 inches above the belt conveyor, which is a comfortable working height. This allows sufficient clearance to prevent birds hung in shackles from dragging across those on the belt, except when excessive numbers accumulate on the belt.

(6) Some of the undergrade birds are removed from the belt by the sorters positioned prior to the grading operation and thus fewer birds are left to be graded.

The undesirable features of this grading area are as follows:

(1) Because the birds are mingled together on the belt conveyors, the production rates of the first two or three graders on the line are restricted since they have to separate the birds before grading them.

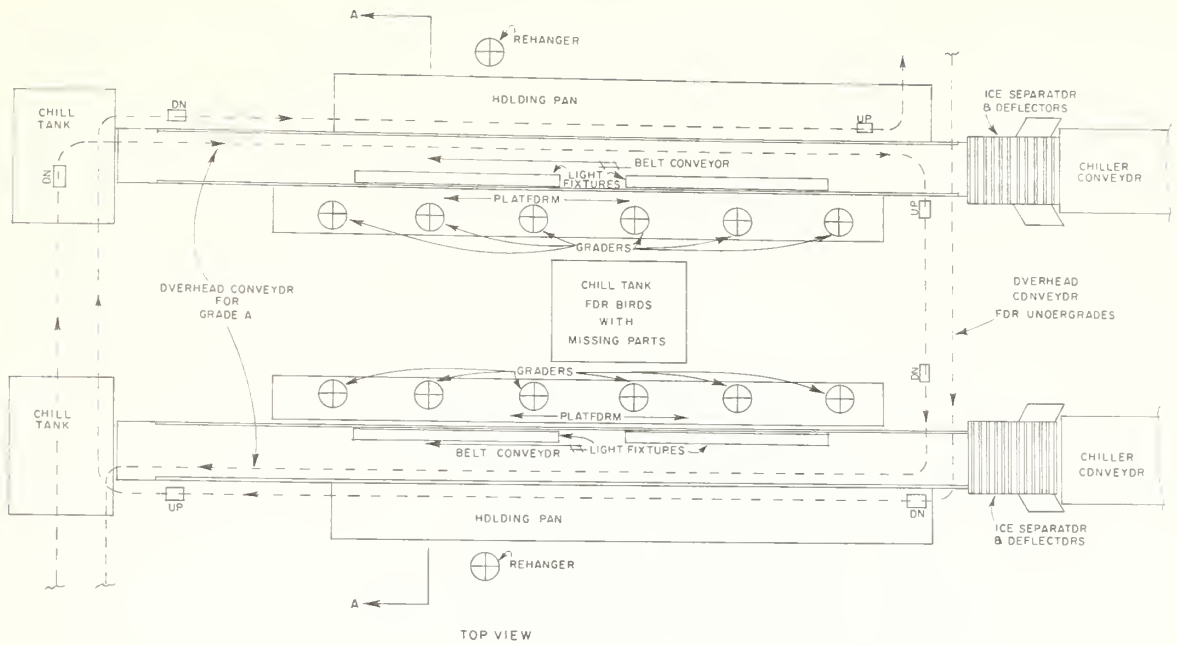

TOP VIEW

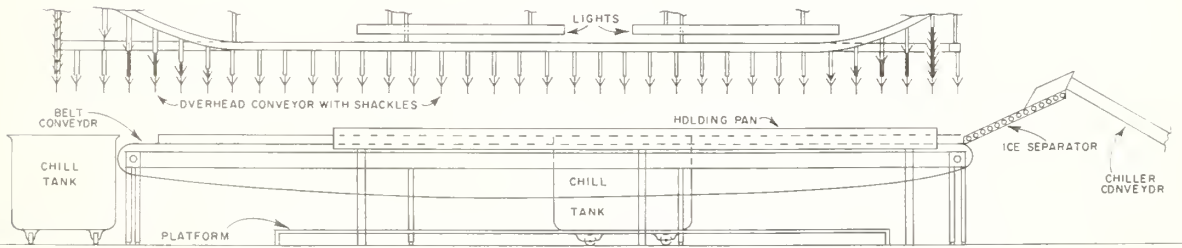

SIDE VIEW

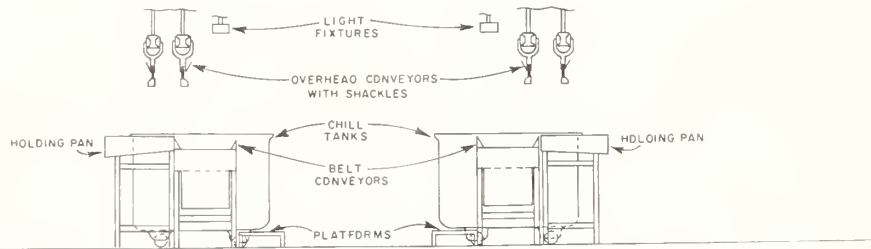

SECTION A-A



Figure 7.--Layout of broiler grading area in plant C.

(2) Likewise, some of the graders near the end of the belt conveyors have to wait for empty shackles to hang their grade A birds, because many of the shackles have been filled by other graders.

(3) The grading function is not equally distributed among the graders; the first graders have to grade more birds than those at the opposite end of the grading belts.

(4) The grading operation occupies an excessive amount of floorspace relative to grading operations in other plants.

(5) Accuracy and efficiency are less than optimum. Fourteen persons plus support personnel are involved in sorting, grading, and rehangng; some are working close to their maximum capability, whereas others are not.

### Suggested Improvements

The belt conveyors from which the grading is performed frequently become overcrowded, and the selection and handling of birds in the grading process become more difficult. Grading would probably improve if the plant processing volume were reduced. A 10-percent reduction might facilitate a 20-percent increase in grading efficiency. The plant is operating above its design capacity.

Numerous changes could be made to improve the grading and rehangng operations in this plant. These changes should be based on standard industrial engineering principles, such as minimizing congestion, wasted motions, excessive handling, unnecessary equipment, and avoidable delays. Changes should be directed toward improved flow patterns and methods of increasing accuracy, such as equalizing the workload among employees.

Some examples of how the grading and rehangng operation could be improved are as follows: (1) Use wider but shorter belt conveyors to reduce the amount of intermingling of birds by allowing them to be spread out over a wider area; (2) grade on both sides of each belt conveyor to more evenly distribute the workload--(equipment changes, such as the wider belt conveyor and relocation of holding pans and overhead conveyors, would be necessary); (3) use dividers above the belt conveyor to turn all the birds in one direction so as to make handling them easier; and (4) significantly improve the quality of birds to be graded and thus increase the accuracy and efficiency of grading.

## METHODS AND FACILITIES FOR GRADING TURKEYS

### Plant D

#### Description

Plant D is a turkey processing plant with an annual volume of approximately 12 million birds. Many of the larger turkeys are marketed as further processed products, including cooked and cut up, whereas many of the smaller ones are marketed as whole ready-to-cook birds. Grading whole birds

is supervised by two USDA licensed resident graders assisted by three authorized graders.

Facilities and work-station locations for whole-bird grading are illustrated in figure 8. Whole birds are graded while being transported by a 30-inch-wide, brown, variegated belt conveyor between the chilling machines and the bagging operation. Figure 9 shows the 30-inch-wide dark belt conveyor and a 28-inch-wide white belt conveyor that transport the grade A birds to the packaging area.

Each bird is turned over by a grader to check the entire bird. This first grader randomly selects birds from the belt conveyor and grades them. Those meeting the grade A standards are pulled from the 30-inch-wide belt conveyor and pushed down a chute to the right of the grader. At the bottom of the chute, the birds slide onto a 15-inch-wide belt conveyor, which carries them to a higher elevation. Here they are transferred to another chute, which takes the grade A birds back to the 30-inch belt conveyor at approximately 9 feet from where they were taken from it. Birds not meeting the grade A standards are pushed down another chute to the left of the first grader, which carries the undergrade birds to a 28-inch-wide belt conveyor. From there they are transferred to the cut-up line and shackled by rehangers.

The birds not selected by the first grader continue along the 30-inch-wide belt to the next station, where they are graded by one of two graders located on opposite sides of the belt. They allow those birds meeting the grade A standards to continue along this belt. The undergrade birds are placed on an 18-inch-wide belt conveyor located under this grading belt, which takes them to the 28-inch-wide belt conveyor from which they are hung on the cut-up line. Thus, the undergrade birds are moved to the cut-up line and the grade A birds continue along a 28-inch belt to the packaging area.

All sizes of turkeys from fryers to large toms are graded on the same line. The 30-inch-wide belt conveyor provides sufficient space to separate the birds as they pass in front of the three graders. The belt is dark brown and has a variegated surface. The grading belt is 36 inches above the floor. Side rails extend 3 inches above the belt to keep the birds on it. Chutes are attached to the conveyor frame and fit into openings in the side rail. Light fixtures, 6 feet 4 inches above the floor, extend over the grading area and are offset from the center of the belt by 6 inches on the side with two graders.

The chutes are stainless steel with 3-inch-high sides formed by bending the steel. The chutes on both sides of the first grader are 36 inches above the floor, where they are attached to the grading belt conveyor.

The 28-inch-wide undergrade belt conveyor has a smooth surface. Shelves, 8 inches wide with 3-inch-high sides, are on both sides of this conveyor. Chill tanks are situated at each end of the undergrade conveyor, and above its center is an overhead conveyor. Shackle clearance above the belt is 10-1/2 inches; the shackles are 12 inches on center. The overhead and belt conveyors travel in the same direction.

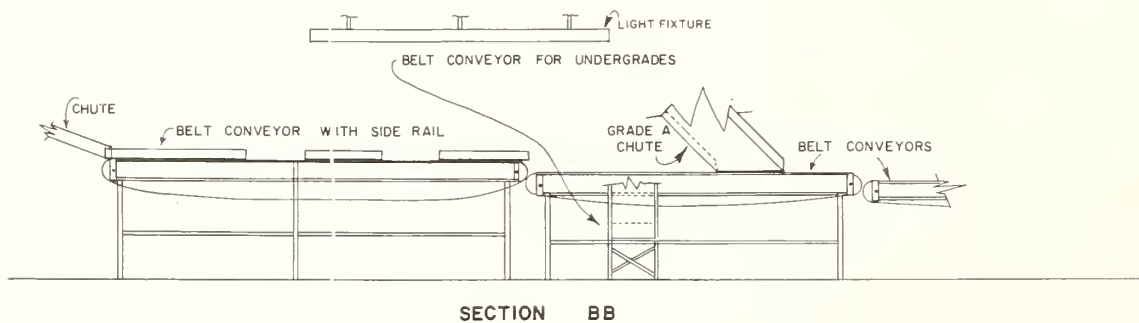
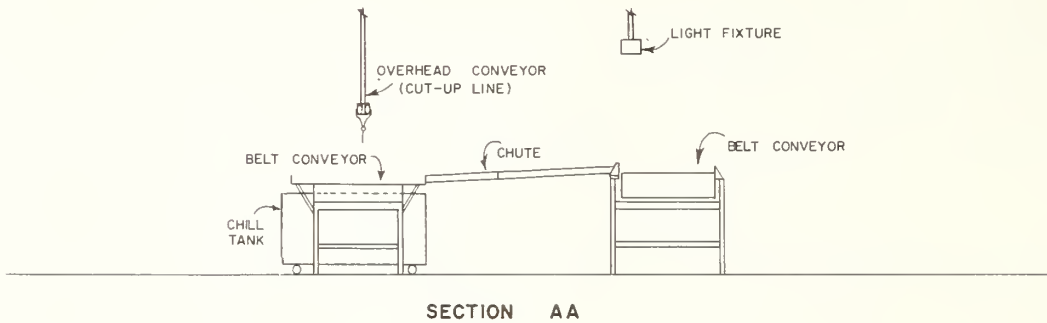
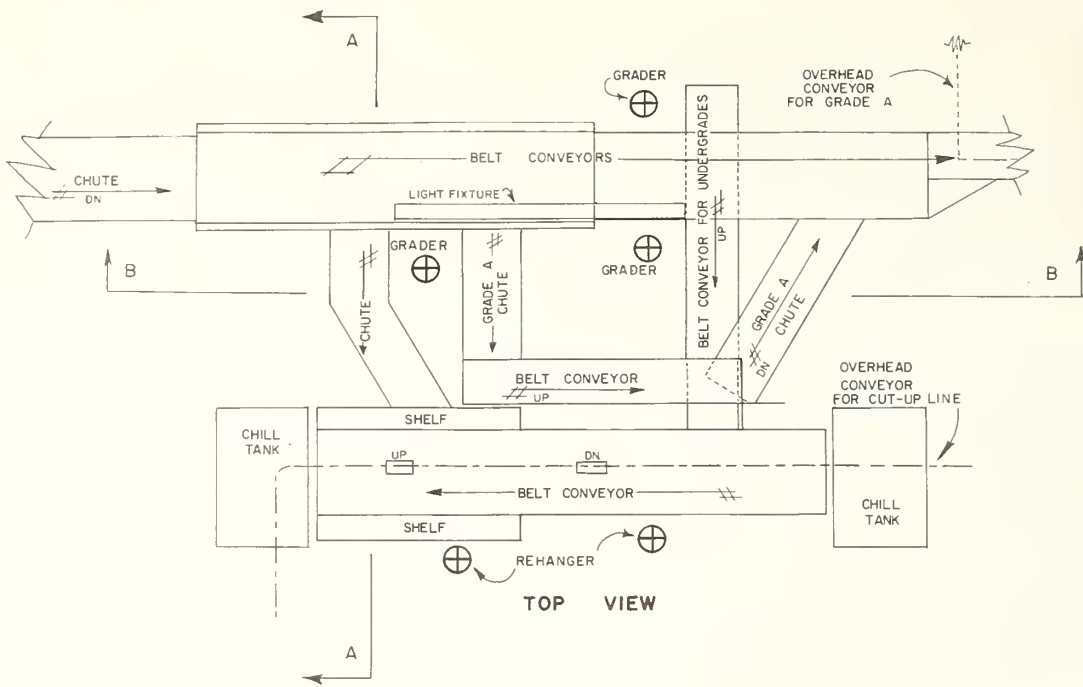
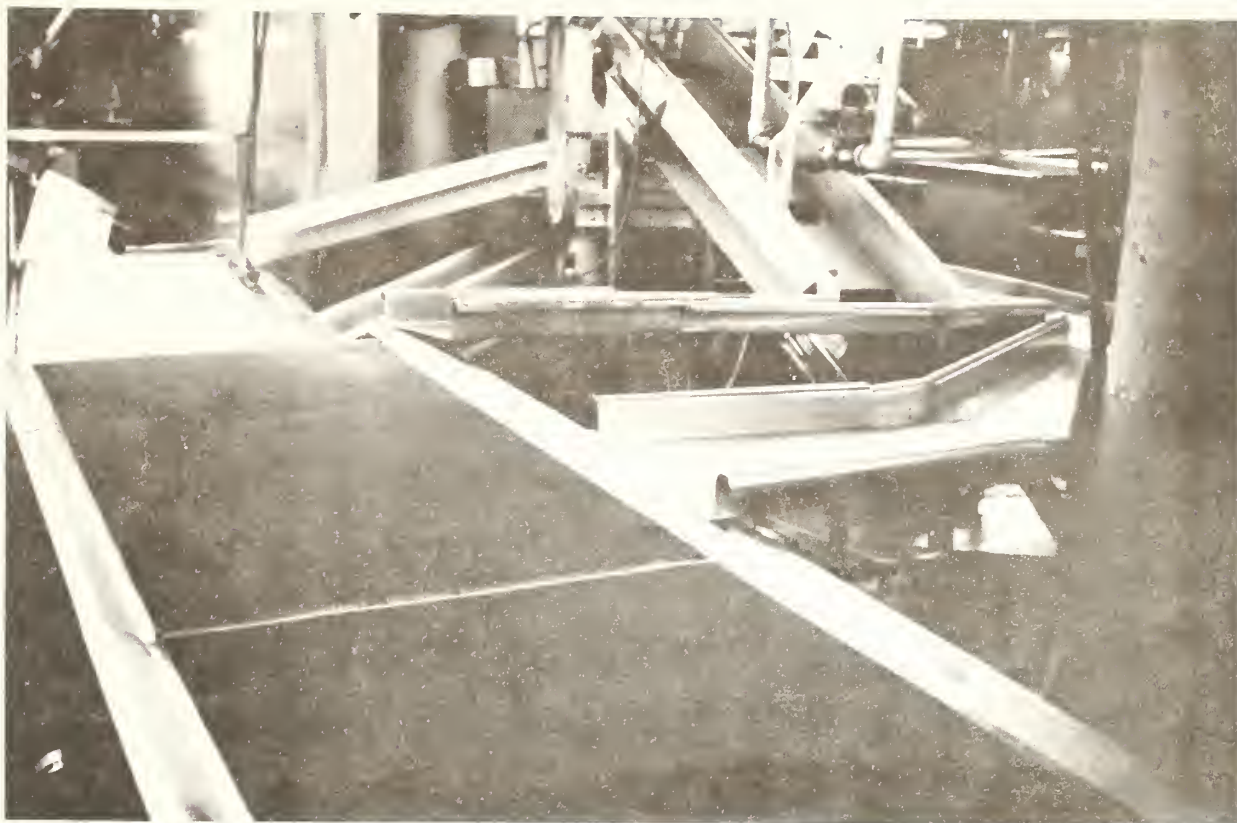

Figure 8.--Layout of turkey grading area in plant D.





PN-6243

Figure 9.--Belt conveyor for grading birds as they pass from the chiller to the white belt (background).

The desirable features of this grading area are as follows:

- (1) Birds graded by the first grader are diverted around the other two graders, so that graded and ungraded birds are not intermingled.
- (2) Lifting of birds is minimized and thus reduces fatigue while enabling the graders to examine all sides of the birds. The birds are rolled over on the belt to facilitate viewing all sides. Undergrade birds are pulled from the belt at the first grading position; however, they must be lifted from the belt at the other two grading positions.
- (3) The dark-brown, variegated belt on which the birds are moved is conducive to grading because it is easy on the eyes. This color is a pronounced contrast to the color of the birds. Being variegated, the belt transports birds smoothly and effectively with no buildups.
- (4) Each of the two graders located across the line from each other can split the workload evenly, yet they can substitute for each other for short periods when one has to be away temporarily.

(5) Lights extend the length of the grading area.

(6) Birds are presented at an acceptable height so that the grader can see them clearly.

(7) Each grader has adequate space on both sides.

The undesirable features of this grading area are as follows:

(1) The grading area has inadequate space for maneuvering from front to back of the workplace, and accessibility is restrictive, particularly for two of the grading positions.

(2) There are no facilities for reconditioning birds to meet grade standards. The undergrade birds must go to an undergrade belt, from which it is difficult to get them back to the grade A belt.

(3) Because the lights are over the grading belt, they shine in the graders' eyes.

(4) The belt grading system works well for large turkeys. However, the time required to roll each bird over occupies an increasingly higher proportion of the graders' time when more birds are being graded per minute.

(5) Safety and noise levels at the grading area could be a problem. A belt conveyor operating about 5 to 6 feet above the floor and behind one of the graders could be a safety hazard. The grader has to go under a chute while stepping over another belt conveyor in order to get to and from the grading position. This is inconvenient and unsafe. Noise at the grading area is relatively high because numerous machines are operating close to the graders.

(6) The floor of the grading-packaging-chilling areas of the plant is at different levels. The result of adding these areas to an existing plant does not contribute to the convenience of product or personnel movement throughout these areas of the plant, nor does it contribute to safety.

(7) Welfare facilities are excessively far from the grading area.

(8) The grading office is on the opposite side of the plant from the grading area.

### Suggested Improvements

The plant is being overutilized when viewed from its design criteria, which have created congestion and less than ideal product and employee flow patterns throughout; however, the plant and the grading operation are relatively efficient. Because of space limitations, ways to improve the operation are restricted, although some improvements can be made within these limitations.

A table is needed for reconditioning birds to meet grade standards so as to increase the percentage of birds being classified as grade A. A table could

be located adjacent to the chill tank at the discharge end of the belt conveyor under the overhead conveyor for the cut-up operation. After reconditioning, the birds would be returned to the grading belt for regrading.

Lighting could be improved by placing a light fixture above and slightly behind each grader, so that the light is directed on the birds without shining in the graders' eyes.

Safety shields should be installed between the graders and the belt conveyors, and lift-up gates could be installed in the chutes to improve the accessibility of the grading positions.

Although an "ideal" grading-station layout can never be achieved in this remodeled plant setting, a high degree of grading accuracy and efficiency can be achieved.

## Plant E

### Description

Plant E is a turkey processing plant with an annual volume of approximately 8 million birds. Most of them are large hens and toms. The production drops to about 50 birds per minute when the large toms are being processed. Most of the undergrades are marketed locally for further processing. Since the more desirable market is for grade A, whole, ready-to-cook birds, the firm strives for a high percentage of grade A birds.

Grading is supervised by a USDA licensed resident grader assisted by authorized graders. Whole birds are graded primarily in the packaging room on a 14-inch-wide belt conveyor. They are stuffed with giblets just prior to grading.

The layout of facilities in the grading area is shown in figure 10. Birds removed from the drip line are transported to the grading area along the belt conveyor, lying on their backs and crosswise (fig. 11). The grader observes the front of the bird. If grade A standards are met, the grader grasps the bird by the hocks, lifts it until it rests on the neck-breast part, and examines its back side. If the entire bird meets the standards, it is placed on its back on the belt conveyor and moved to the next work station, where it is hung by the wing from an overhead conveyor and transported to be packaged. Undergrade birds are collected in a chill tank beside the grader.

The 16-inch-wide belt conveyor and the two 12-inch stainless steel shelves on either side provide space to separate the birds as they pass in front of the grader. The conveyor and shelves are 38 inches above the floor, which is 1 inch above the normal sitting-standing working height for women.

Light fixtures, 6 feet 8 inches above the floor, run parallel to the grading belt conveyor. They are directly above the outer edge of the stainless steel shelf, on the same side of the conveyor as the grader, and almost directly above the grader's head.

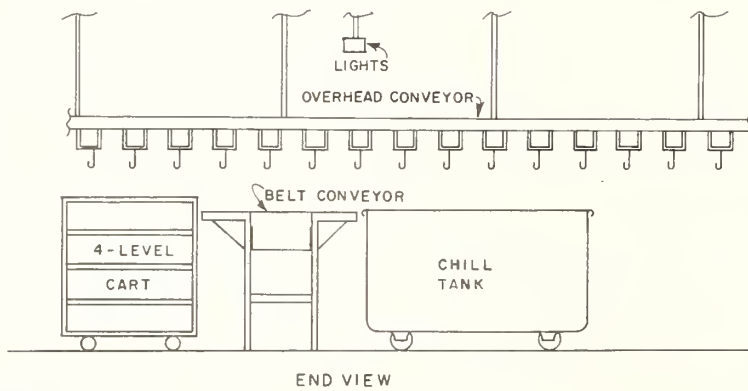
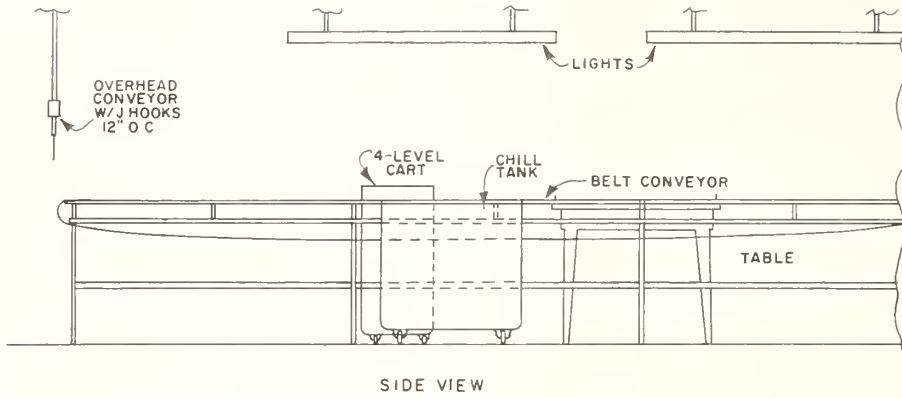
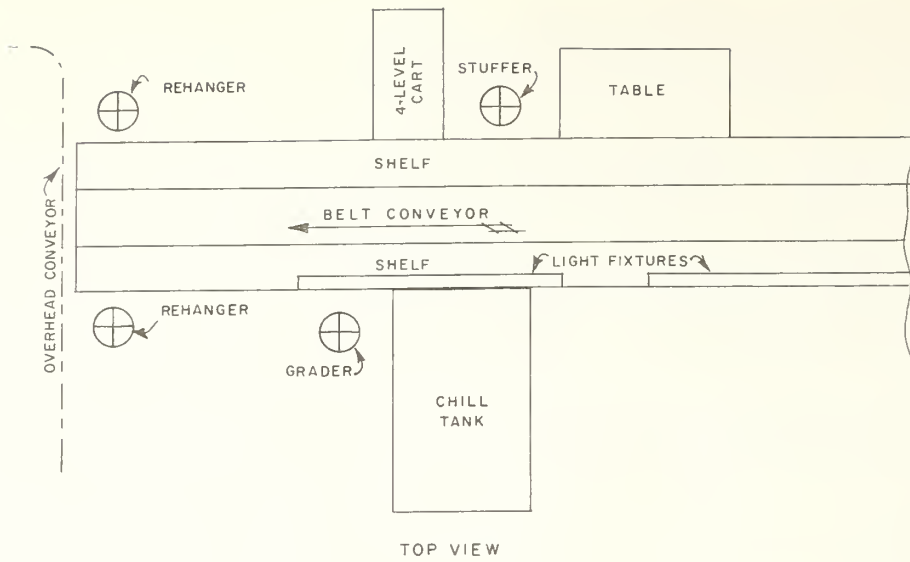

Figure 10.--Layout of turkey grading area in plant E.





PN-6244

Figure 11.--Turkeys being moved along the belt conveyor to the grading area.

Shackles on the overhead conveyor are 12 inches on center and 10 inches above the belt conveyor. The J hooks are attached at two points on the overhead conveyor.

The desirable features of this grading area are as follows:

- (1) The belt conveyor and wide shelves on either side provide an excellent working surface at approximately the most desirable height (fig. 12).
- (2) The facilities are easy to clean because all the equipment is movable.
- (3) Lifting of the birds is minimized because the grader is able to see the back without lifting the entire bird. Shackles used in transporting the birds to the packaging area are at a convenient height above the belt conveyor.
- (4) Grading decisions are minimized since all undergrades are deposited in a chill tank.
- (5) Adequate space is available for another grader when needed.



PN-6245

Figure 12.--Desirable work height of conveyor for short and tall graders.

- (6) The grader has adequate working space.
- (7) The view of the birds at the grading area is good.
- (8) Light fixture location and candle power are satisfactory.

The undesirable features of this grading area are as follows:

(1) No facilities are provided to recondition birds to meet grade standards. A higher percentage of grade A birds could probably be achieved with some reconditioning.

(2) Birds must be lifted on one end to grade the back side.

#### Suggested Improvements

Since the grading operation and facilities are among the most desirable in the industry, improvements are limited.

A table or rack is beneficial for reconditioning some of the birds, especially when the price spread between grade A and undergrade is appreciable.

## Plant F

### Description

Plant F is a turkey processing plant with an annual volume of approximately 9 million birds. Ready-to-cook, 8- to 10-pound fryer turkeys constitute a major share of the plant production. Almost all these birds receive additional processing in the same plant. The firm uses the "USDA Grade A" shield on its products and strives to achieve a high percentage of grade A.

Grading is by a USDA licensed resident grader assisted by authorized graders. Whole-bird grading is performed primarily in the evisceration room. After the birds have been chilled, drained, and removed from the drip line, they are transported by a 12-inch-wide belt conveyor to the grader.

The layout of the grading area is shown in figure 13. Plant F has "producer grading," with the grade data being recorded. This is available to all qualifying plants on request. As the birds are transported by the belt conveyor (fig. 14), the grader holds each one by a wing and observes the condition of the breast side. If the standards for grade A are met, the bird is turned on end and the back side is checked. Grade A birds are left on the belt, continuing to the next work station, where they are hung in shackles attached to the overhead conveyor. Giblets are stuffed in the birds after they leave the grading area. Undergrade birds are deposited in chill tanks (fig. 14) behind the grader. Space around the grading area is ample, as shown in figure 14, and the noise level, which is relatively low at approximately 80-85 decibels of the A scale, contributes to an effective work station.

The J hooks attached to the overhead conveyor above the grading belt are 6 inches on center, with a clearance of 22 inches between the bottom of the hooks and the conveyor belt. The top side of the belt conveyor is 33 inches above the floor, and the outer edges of the sloped stainless steel shelves are 37 inches above the floor.

A 6-foot light fixture, 6 feet 10 inches above the floor, is suspended above the outer edge of the shelf on the grading side of the belt conveyor.

The desirable features of this grading area are as follows:

- (1) The area is uncongested, well lit, and relatively quiet.
- (2) The equipment and area are easy to clean.
- (3) Decisions on disposal of undergrades are minimized since all undergrades are dropped into a chill tank.
- (4) Sloped shelves on either side of the grading belt protect the birds from falling onto the floor.

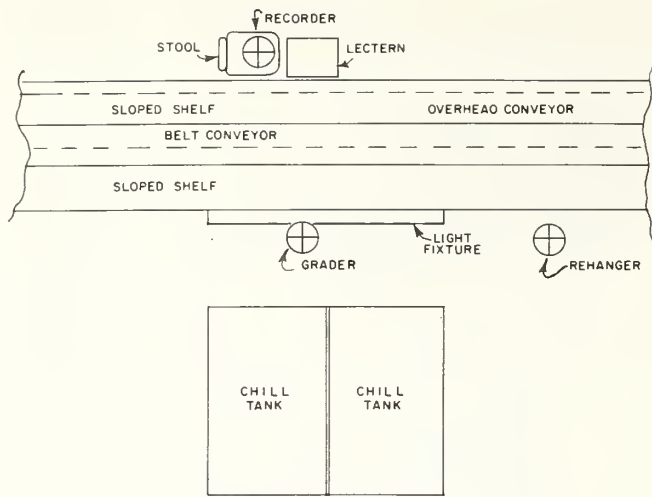

TOP VIEW

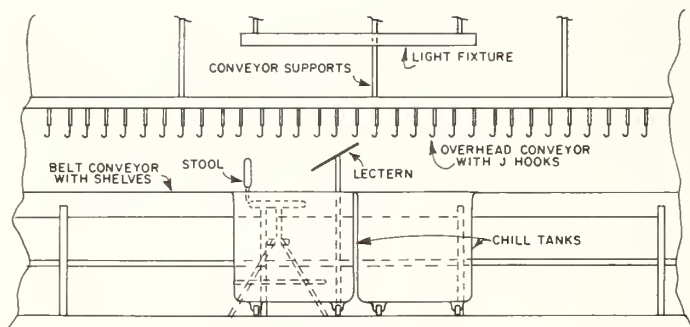

SIDE VIEW

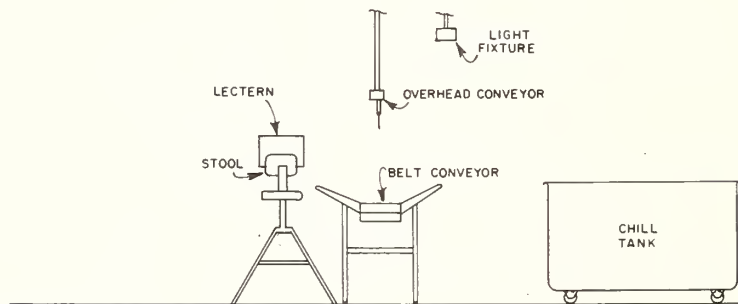

END VIEW

Figure 13.--Layout of turkey grading area in plant F.





PN-6246

Figure 14.--Grading area with chill tanks for undergrade birds (foreground).

(5) Birds are moved past the grading position at a constant pace.

(6) Grading position and responsibilities are conducive to rotation and thereby reduce fatigue.

(7) Lights are adequate and well located.

(8) The workspace is sufficient and safe.

(9) The grading area is near the grading office.

The undesirable features of this grading area are as follows:

(1) The grading belt, which is 33 inches above the floor, is too low for most graders, especially with the higher edge of the shelves, which are 37 inches above the floor.

(2) J hooks moving past the grading area at 4 feet 8 inches above the floor could be hazardous because they are close to eye level.

## Suggested Improvements

The grading operation in this plant is smooth, with a relatively satisfactory work-station layout; it is in desirable surroundings and has ample support facilities. However, some of the smoothness can be attributed to the plant's reduced production, which was not related to grading.

Suggested improvements include raising the overhead conveyor approximately 2 feet at the grading area for safety reasons and raising the conveyor belt a few inches to reduce worker fatigue, especially for taller graders.

## LITERATURE CITED

- (1) Edgar, A. S.  
1977. Broiler industry men probe lowering production costs. *The Poultry Times*, Southeastern ed., Poultry and Egg News, Inc., Gainesville, Ga., p. 12.
- (2) Harris, C. E., Goble, J. W., and Kozlowski, R.  
1972. Planning a wholesale poultry layout in a multiple-occupancy building. U.S. Dept. Agr., Mktg. Res. Rpt. 918, 18 pp.
- (3) Illuminating Engineering Society, Inc.  
1966. Illuminating Engineering Society lighting handbook. 57 pp. New York.
- (4) Lehrer, R. N.  
1961. Work simplification, creative thinking about work problems. 394 pp. Prentice-Hall, Inc., Englewood Cliffs, N.J.
- (5) Reed, R., Jr.  
1961. Plant layout: Factors, principles, and techniques. 459 pp. Richard D. Irwin, Inc., Homewood, Ill.
- (6) U.S. Department of Agriculture.  
1976. Poultry graders handbook. AMS PY-instruction No. 910, Sect. 3, pp. 31-33.
- (7) \_\_\_\_\_  
1976. Regulations governing the voluntary grading of poultry products and rabbit products and United States classes, standards, and grades with respect thereto (7 CFR part 70) - effective July 15, 1976. 16 pp. Washington, D.C.
- (8) \_\_\_\_\_  
1977. Poultry grading manual. Agr. Mktg. Serv., Agr. Handb. 31, 30 pp.

Poultry Grading Regulations <sup>1/</sup>

Part 70 - Grading of Poultry Products and Rabbit Products and United States Classes, Standards and Grades With Respect Thereto.

Section 70:34, "Application for Grading Service in Official Plants; Approval.

Any person desiring to process and pack products in a plant under grading service must receive approval of such plant and facilities as an official plant prior to the rendition of such service. An application for grading service to be rendered in an official plant shall be approved according to the following procedure: Survey. When application has been filed for grading service, as aforesaid, the State supervisor or his assistant shall examine the grading office, facilities, and equipment and specify any additional facilities or equipment needed for the service. When the plant survey for poultry . . . grading has been completed and approved in accordance with the regulations in this part, service may be installed."

Section 70:35, "Rejection of Application.

Any application for grading service may be rejected by the Administrator . . . (e) whenever the applicant, after an initial survey has been made in accordance with 70:34, fails to bring the grading facilities and equipment into compliance with the regulations within a reasonable period of time;"

Grading Facility and Equipment Requirements <sup>2/</sup>

Section 3

1. Facilities and Equipment Required for Resident Federal-State Graders

A. To Be Furnished by the Plant:

- (1) A metal stem thermometer. The stem must be long enough to reach the center of the largest ready-to-cook carcass or poultry product that is to be graded or examined for condition.
- (2) A scale, graduated in ounces or less, for weighing individual birds.
- (3) A scale, graduated in 1/4-pound or less graduations, for use in weighing poultry packed in bulk containers. When purchasing new scales, plant management should consider scales marked according to the metric system as well as in ounces and tenths of ounces.

---

<sup>1/</sup> From U.S. Department of Agriculture (7).

<sup>2/</sup> From U.S. Department of Agriculture (6).

(4) Test weights of adequate number and sizes to check the accuracy of the scale at the weight level of poultry packed in the plant.

(5) A desk and separate four-drawer file cabinet equipped with a locking device. These facilities should be located in an adequate, acceptable office space.

(6) A drill with a steel bit of the size to accommodate the thermometer stem to be used for inserting into a frozen product for temperature determination.

B. To Be Furnished by the State Supervisor:

(1) Grading certificates and memorandums.

(2) Other report forms.

(3) Complete set of instructions.

(4) Official rubber die grading stamps. (The cost of the dies are billed to the firm.)

(5) USDA badge or emblem to be worn by the grader.

(6) A government lock for the files.

(7) File folders for graders' records.

C. To Be Utilized by Federal-State Graders - Clean washable clothing or uniform and proper head covering. Clothing and head covering worn must be other than that used for street wear.

## II. Surveys

When a plant is surveyed, the Federal-State supervisor will approve the grading office, facilities, and equipment. One or more grading stations will be approved. The grading stations or grading area are not to be changed without prior concurrence from the Federal-State supervisor.

## III. Grading Stations

The following are minimum requirements for grading facilities:

A. A minimum of 36 inches (preferably 42 inches) linear space for each authorized grader.

B. Line shackles, grading belts, tables, and bins are to be at proper heights to facilitate accurate and efficient grading. Proper height is defined to mean authorized grader can--

(1) Grade products without bending, stooping, stretching, etc., to reach products.

(2) See every bird or part in its entirety.

(3) Have grading area free of obstructions.

C. Grading is not to be performed on curves, inclines, declines, etc.

D. Line shackles are to be marked for easy identification. The markings are to be located so graders can identify without losing eye contact with the products they are grading.

E. Stands, if used, must be of sturdy and safe construction. If over 12 inches high, guardrails must be provided. The stands must be a minimum of 2 feet wide and the area must completely cover the full length of the grading station.

F. Belts and tables must be of size to handle the maximum volume of product to be graded without piling up.

#### IV. Lighting Requirements for Grading Facilities

A. Quantity of Illumination - The initial installation of lighting equipment should provide lighting intensity in the range of 90 to 110 foot-candles. This will insure the minimum requirements of 50 foot-candles at the grading station after the normal decrease in the lighting level occurs. The luminaires (fixtures) are to be at least 48 inches in length and of the fluorescent type, with at least two lamps but preferably four. Mercury vapor lights or other satisfactory lighting may be used when approved by the national office. The fixtures must be parallel to the working surface and extend the full length of the grading area. Other installations may be satisfactory if the criteria for light intensity and foot-candles are met.

B. Quality of Illumination - The lighting must have the color and spectral quality of daylight. (By definition, the ideal for grading purposes is north sky daylight having a color temperature of 7500 K.) It should be generally diffused, with enough direction to allow depth perception, and be uniform over all working areas with no glare and no crosslighting.

C. Maintenance - A regular scheduled system of maintenance is to be established to insure that luminaires and room surfaces are kept clean and in proper condition.

(1) Check illumination level periodically with a light meter. Take the readings at 2-month intervals.

(2) Replace lamps when the illumination falls below 50 foot-candles.

(3) Clean lighting equipment at regular intervals.

(4) Provide for easy access to all luminaires.



EXHIBIT 1  
SUMMARY OF SPECIFICATIONS OF QUALITY FOR INDIVIDUAL CARCASSES OF  
READY-TO-COOK POULTRY AND PARTS THEREFROM  
(Minimum Requirements and Maximum Defects Permitted)

FACTOR	A QUALITY	B QUALITY	C QUALITY
CONFORMATION			
Breastbone	Normal Slight curve or dent	Moderate deformities Moderately dented, curved or crooked	Abnormal Seriously curved or crooked
Back	Normal (except slight curve)	Moderately crooked	Seriously crooked
Legs and Wings	Normal	Moderately misshapen	Misshapen
FLESHING	Well fleshed, moderately long, deep and rounded breast	Moderately fleshed, considering kind, class and part	Poorly fleshed
FAT COVERING	Well covered--especially between heavy feather tracts on breast and considering kind, class and part	Sufficient fat on breast and legs to prevent distinct appearance of flesh through the skin	Lacking in fat covering all parts of carcass
PINFEATHERS			
Nonprotruding pins and hair	Free	Few scattered	Scattering
Protruding pins	Free	Free	Free
EXPOSED FLESH			
Carcass weight	Breast and legs	Breast $\frac{2}{1}$ / and legs	Part
Minimum	None	$\frac{1}{4}$ "	No
Maximum	None	$1\frac{1}{2}$ "	limit
None	None	$1\frac{1}{2}$ "	
Over 1½	None	$1\frac{1}{2}$ "	Moderate amount of the flesh normally covered
lbs	None	2"	
Over 6	None	3"	
lbs	None		
Over 16	None		
None			
lbs			

DISCOLORATIONS	<u>3/</u>								No <u>4/</u> limit
None	1 1/2 lbs	1/2"	1"	1/4"	1"	2"	1/2"	2"	
Over 1 1/2 lbs	6 lbs	1"	2"	1/4"	2"	3"	1/2"	3"	
Over 6 lbs	16 lbs	1 1/2"	2 1/2"	1/2"	2 1/2"	4"	1 1/2"	4"	
Over 16 lbs	None	2"	3"	1/2"	3"	5"	1 1/2"	5"	
Disjointed bones	1								No limit
Broken bones	None								No limit
Missing parts	Wing tips and tail								Wing tips, wings and tail Back area not wider than base of tail extending to area between hip joints
FREZZING DEFECTS (When consumer packaged)		Slight darkening over the back and drumsticks (Few small 1/8" pockmarks for poultry weighing 6 lbs or less and 1/4" pockmarks for poultry weighing more than 6 lbs) Occasional small areas showing layer of clear or pinkish ice			Moderate dried areas not in excess of 1/2" in diameter May lack brightness Moderate areas showing layer of clear, pinkish or reddish colored ice				Numerous pockmarks and large dried areas

1/ Total aggregate area of flesh exposed by all cuts and tears and missing skin, not exceeding the area of circle of the diameters shown.

2/ A carcass meeting the requirements of A quality for fleshing may be trimmed to remove skin and flesh defects, provided that no more than one-third of the flesh is exposed on any part and the meat yield is not appreciably affected.

3/ Flesh bruises and discolorations such as blue back are not permitted on breast and legs of A quality birds. Not more than one-half of total aggregate area of discolorations may be due to flesh bruises or blue black (when permitted) and skin bruises in any combination.

4/ No limit on size and number of areas of discoloration and flesh bruises if such areas do not render any part of the carcass unfit for food.

Source: U.S. Department of Agriculture (8).

PLANT SURVEY FOR POULTRY GRADING

**INSTRUCTIONS:** Check applicable blocks in Items 1 and 2. Answer all questions in Items 3 through 6 by checking "Yes" or "No" blocks. Use "Remarks" sections when further explanations are required.

NAME AND ADDRESS (City and State) OF PLANT	DATE SURVEYED	PLANT NUMBER
<input type="checkbox"/> INITIAL SURVEY		<input type="checkbox"/> RE-SURVEY

**1. TYPE OF OPERATION PERFORMED**

<input type="checkbox"/> ICE PACK	<input type="checkbox"/> FREEZING	<input type="checkbox"/> EVISCERATING	<input type="checkbox"/> CUT UP	<input type="checkbox"/> OTHER
<input type="checkbox"/> CHILL PACK	<input type="checkbox"/> PACKAGING ONLY (Specify) _____			
<input type="checkbox"/> FURTHER PROCESSING (Specify) _____				

**2. CLASS OF POULTRY TO BE GRADED**

<input type="checkbox"/> YOUNG CHICKENS	<input type="checkbox"/> TURKEYS	<input type="checkbox"/> FOWL	<input type="checkbox"/> OTHER (Specify) _____
---	----------------------------------	-------------------------------	--

**3. OFFICE FACILITIES**

		YES	NO
a. Is sufficient office space, desk, adequate heat and light, 4-drawer file cabinet that can be locked, and other necessary furnishings provided for graders? (Give location and description of space in "Remarks") . . . . .	<input type="checkbox"/>		
b. Is the office conveniently located and adequate? . . . . .	<input type="checkbox"/>		
Remarks:			

**4. APPROVED LABELING**

		YES	NO
a. Is the file of approved labeling material available to the grader? . . . . .	<input type="checkbox"/>		
b. Are approvals on file for all labeling bearing official grade mark? . . . . .	<input type="checkbox"/>		
c. Are proofs of new labeling material bearing official grade marks being submitted for approval? . . . . .	<input type="checkbox"/>		
d. Did you discuss labeling with plant management? . . . . .	<input type="checkbox"/>		
Remarks:			

**5. GRADING FACILITIES AND EQUIPMENT**

		YES	NO
a. Is there adequate lighting at all grading and weighing stations? (Show foot candles _____ for each station) . . . . .	<input type="checkbox"/>		
b. Is grading performed on <input type="checkbox"/> SHACKLES <input type="checkbox"/> TABLE <input type="checkbox"/> BELT			
<input type="checkbox"/> OTHER (Specify) _____			





U.S. DEPARTMENT OF AGRICULTURE  
SCIENCE AND EDUCATION ADMINISTRATION  
HYATTSVILLE, MARYLAND 20782

OFFICIAL BUSINESS  
PENALTY FOR PRIVATE USE \$300

POSTAGE AND FEES PAID  
U. S. DEPARTMENT OF  
AGRICULTURE  
AGR 101

